

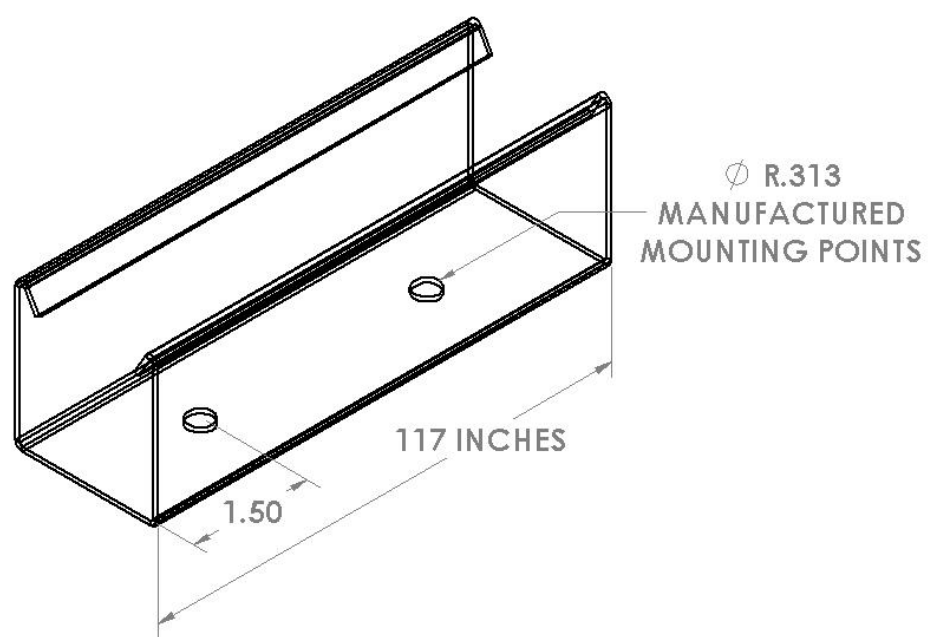

<b>Part Number</b>  <b>SDS-WM-RCW-100-ST</b>	<b>Nominal Dimensions</b>  2" x 2" x 120"	
<b>Description</b>  The wall-mounted 2" x 2" Secure Raceway encloses and protects secure network cables. The Secure Raceway comes in 10-foot sections <sup>1</sup> in a 100' kit <sup>2</sup> . Manufactured mounting points on the Raceway allow a simplified, labor-saving mounting technique.  NOTE: The SDS-WM-RCW-100-ST kit contains Raceway only. For Raceway and TopCap, see the SDS-WM-RCW-ST kit.		
<b>Specifications</b> <ul style="list-style-type: none"> <li>• 16-gauge electro-galvanized steel</li> <li>• Components:           <ul style="list-style-type: none"> <li>– High Security Raceway: Length 117" x Width 1.9" x Height 1.8"</li> </ul> </li> <li>• Total length: Ten (10) 117" sections of Raceway</li> <li>• Total weight: 127 lbs</li> <li>• Two (2) manufactured mounting points in each 117" section           <ul style="list-style-type: none"> <li>– 1½" from ends of each 117" raceway</li> <li>– Located along raceway center line</li> </ul> </li> </ul> <p>Powder Coat Finish: White Textured</p> <p><sup>1</sup>Nominal. Actual length of Raceway and TopCap sections is 117.0"  <sup>2</sup>Nominal. Actual footage of Raceway per kit is 97.5'</p>		

	HOLOCOM, INC. <a href="mailto:customerservice@holocom.com">customerservice@holocom.com</a> <a href="http://www.holocom.com">www.holocom.com</a>	<b>PART #:</b>  <b>SDS-WM-RCW-100-ST</b>	<b>TITLE:</b>  SECURE RACEWAY - STEEL 100 FT
		All material contained in this document is the property of Holocom, Inc. and may not be reproduced or transmitted (including electronically) without the written consent of Holocom, Inc. Holocom and the Holocom logo are registered trademarks of Holocom, Inc. Other noted marks are trademarks of their respective companies. Holocom products protected by US Pats. 7,183,488; 7,115,814; 7,053,303; 7,049,517; 6,838,616; 5,831,211 and Pats. pending. Made in the U.S.A. Copyright © 2008 Holocom, Inc. All rights reserved.	