

Part Number	Nominal Dimensions
SDS-WM-RCW-ST-05	2" x 2" x 60"

Description

The wall-mounted 2" x 2" Secure Raceway, now available in convenient five-foot lengths in a 50' kit, encloses and protects secure network cables. The Secure Raceway comprises two pieces: the Raceway and TopCap. Manufactured mounting points on the Raceway allow a simplified, labor-saving mounting technique. With the addition of other locking components, the Raceway and TopCap securely lock together.

- Specifications**
- 16-gauge electro-galvanized steel
 - Components:
 - High Security Raceway: Length 60" x Width 1.9" x Height 1.8"
 - High Security TopCap: Length 60" x Width 2.0" x Height 1.8"
 - Total length: 60" sections of Raceway and TopCap (10 each)
 - Total weight: 127 lbs. Raceway and TopCap
 - Two (2) manufactured mounting points in each 60" raceway section
 - 1.5" from each end of 60" raceway
 - Located along raceway center line
- Powder Coat Finish: White Textured

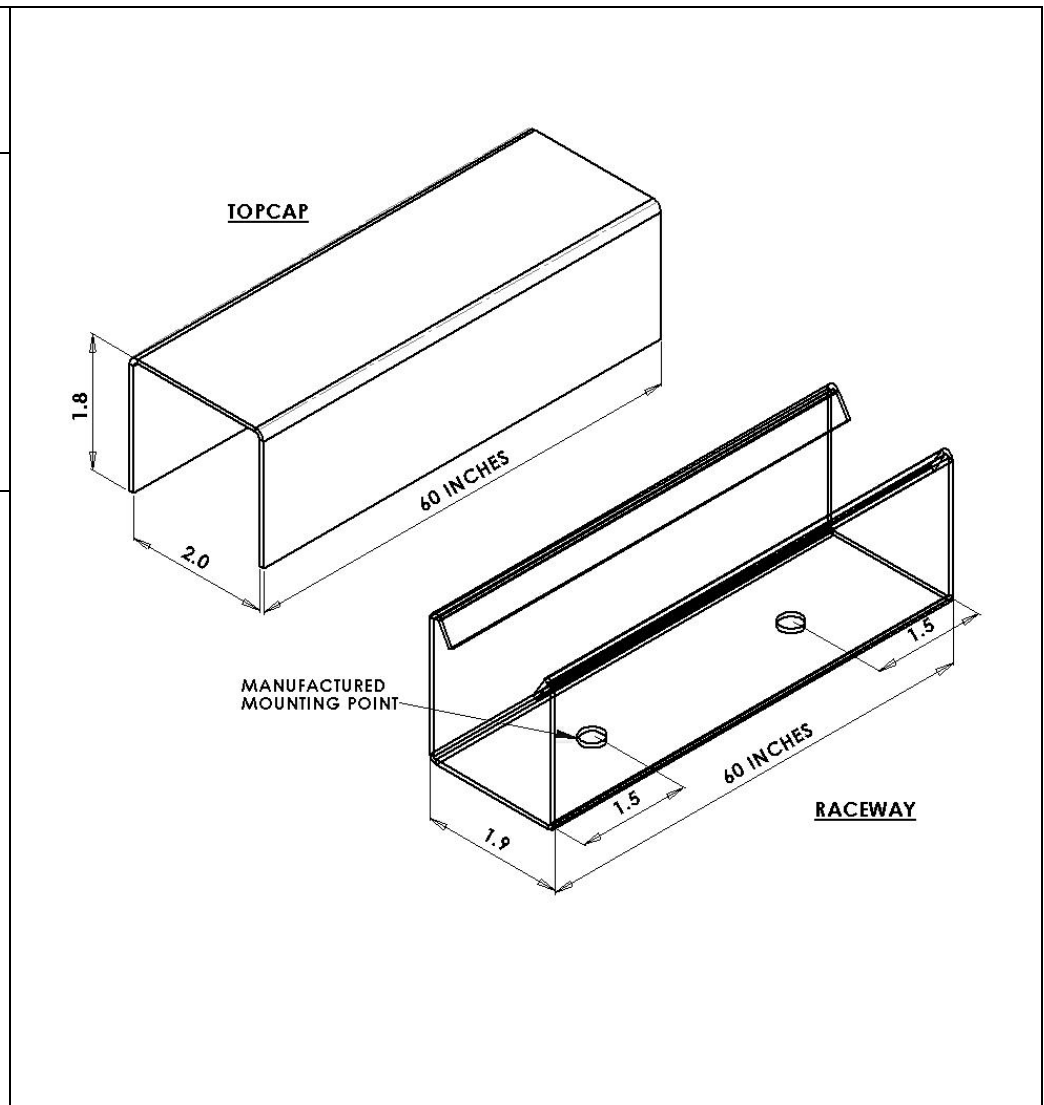

HOLOCOM, INC.
customerservice@holocom.com
www.holocom.com

PART #:
SDS-WM-RCW-ST-05

TITLE:
 SECURE RACEWAY - STEEL 50 FT

All material contained in this document is the property of Holocom, Inc. and may not be reproduced or transmitted (including electronically) without the written consent of Holocom, Inc. Holocom and the Holocom logo are registered trademarks of Holocom, Inc. Other noted marks are trademarks of their respective companies. Holocom products protected by US Pats. 7,183,488; 7,115,814; 7,053,303; 7,049,517; 6,838,616; 5,831,211 and Pats. pending. Made in the U.S.A. Copyright © 2008 Holocom, Inc. All rights reserved.