

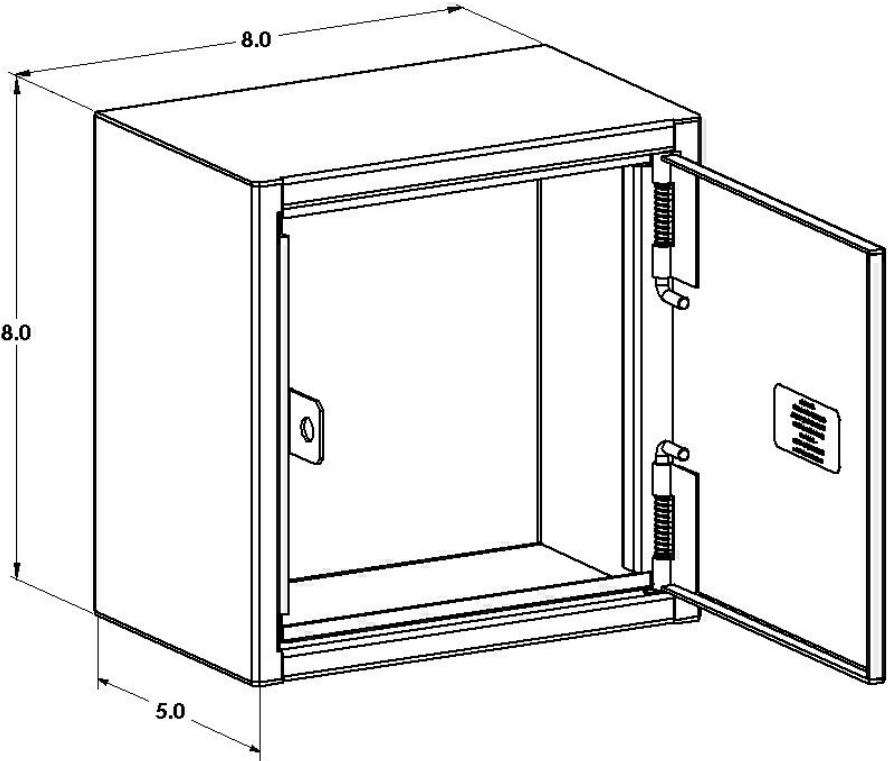

<b>Product Code</b>  <b>SEC-WM-885-H1</b>	<b>Nominal Dimensions</b>  8" x 8" x 5"	
<b>Description</b>  This 16-gauge High Security Enclosure can be mounted on walls or desktops and provides physical security for surface mount boxes or any other connection point. The 885 Enclosure also may be used as a small pull box within the Holocom PDS. The door securely locks using Holocom's patented locking system and the Sargent and Greenleaf® padlock.		
<b>Specifications</b> <ul style="list-style-type: none"> <li>• Height 8" x Width 8" x Depth 5"</li> <li>• 16-gauge electro-galvanized steel with welded seams</li> <li>• Weight: 6 lbs</li> <li>• Single door with security padlock hasp</li> <li>• Tamper resistant design with welded internal hinges</li> </ul> Powder Coat Finish: White Textured		

	HOLOCOM, INC. <a href="mailto:customerservice@holocom.com">customerservice@holocom.com</a> <a href="http://www.holocom.com">www.holocom.com</a>	<b>PRODUCT CODE:</b>  <b>SEC-WM-885-H1</b>	<b>TITLE:</b>  HIGH SECURITY ENCLOSURE
All material contained in this document is the property of Holocom, Inc. and may not be reproduced or transmitted (including electronically) without the written consent of Holocom, Inc. Holocom and the Holocom logo are registered trademarks of Holocom, Inc. Other noted marks are trademarks of their respective companies. Holocom products protected by US Pats. 7,183,488; 7,115,814; 7,053,303; 7,049,517; 6,838,616; 5,831,211 and Pats. pending. Made in the U.S.A. Copyright © 2008 Holocom, Inc. All rights reserved.			