

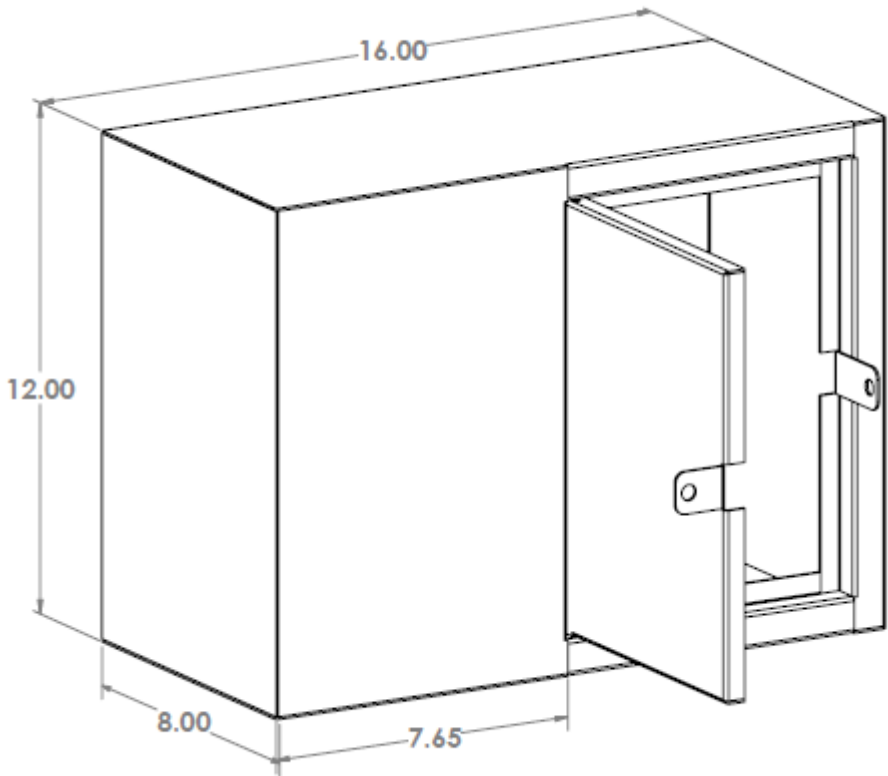

<b>Product Code</b>  <b>SEC-WM-PB14-H1</b>	<b>Nominal Dimensions</b>  12.0" x 16.0" x 8.0"	
<b>Description</b>  This 16-gauge High Security Pull Box enclosure mounts securely to walls and was designed to protect classified cabling and allow for raceway or conduit to exit the front of the enclosure to cross hallways. The PB-14-H1 functions similar to the PB-10-H1 enclosure except it has larger dimensions for larger cable installations. The door securely locks using Holocom's patented door back flange, as well as the Sargent and Greenleaf® padlock.		
<b>Specifications</b> <ul style="list-style-type: none"> <li>• Height 12" x Width 16" x Depth 8"</li> <li>• 16-gauge electro-galvanized steel</li> <li>• Weight: 15.0 lbs</li> <li>• Tamper-resistant design with welded internal hinges</li> </ul> <p>Powder Coat Finish: White Textured</p>		

	Holocom, Inc. <a href="mailto:customerservice@holocom.com">customerservice@holocom.com</a> <a href="http://www.holocom.com">www.holocom.com</a>	<b>PRODUCT CODE:</b> <b>SEC-WM-PB14-H1</b>	<b>TITLE:</b> <b>HIGH SECURITY PULL BOX</b>
<small>All material contained in this document is the property of Holocom, Inc. and may not be reproduced or transmitted (including electronically) without the written consent of Holocom, Inc. Holocom and the Holocom logo are registered trademarks of Holocom, Inc. Other noted marks are trademarks of their respective companies. Holocom products protected by US Pats. 8,733,798; 7,661,375; 7,608,780; 7,183,488; 7,115,814; 7,053,303; 7,049,517; 6,838,616; 5,831,211; 632,763; 619,097; 580,871 and patents pending.          Made in the U.S.A. Copyright © 2015 Holocom, Inc. All rights reserved.</small>			