

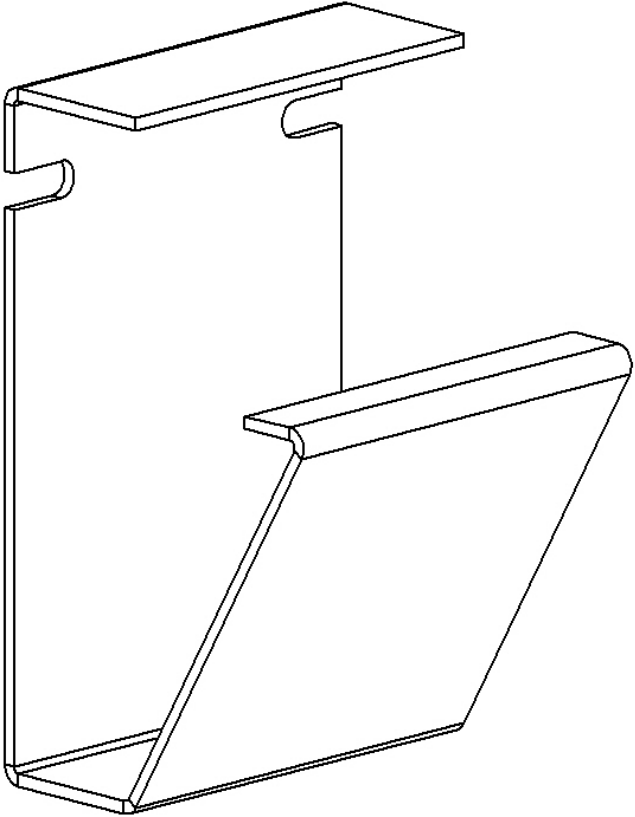

<b>Product Code</b>  <b>SLC-RW-SRJ</b>	<b>Nominal Dimensions</b>  N/A	
<b>Description</b>  The Secure Large Carrier™ Secure Raceway Joint adds rigidity to all Secure Large Carrier™ Raceway or Connector end-to-end joints. Two (2) manufactured mounting points align with the MMPs on the Secure Large Carrier™ Mounting Bracket and Raceway or Connector (SLC-CT-90i/ SLC-CT-90e) allowing simplified, labor-saving installation.		
<b>Specifications</b> <ul style="list-style-type: none"> <li>• 12-gauge electro-galvanized steel</li> <li>• Weight 1.5 lbs</li> <li>• Two (2) manufactured mounting points</li> <li>• Packaged individually</li> <li>• Not powder coated</li> </ul>		

	Holocom, Inc. <a href="http://www.holocom.com">www.holocom.com</a>	<b>PRODUCT CODE:</b> <b>SLC-RW-SRJ</b>	<b>TITLE:</b> <b>SECURE LARGE CARRIER™</b> <b>SECURE RACEWAY JOINT</b>
All material contained in this document is the property of Holocom, Inc. and may not be reproduced or transmitted (including electronically) without the written consent of Holocom, Inc. Holocom and the Holocom logo are registered trademarks of Holocom, Inc. Other noted marks are trademarks of their respective companies. Holocom products protected by US Pats. 7,183,488; 7,115,814; 7,053,303; 7,049,517; 6,838,616; 5,831,211 and patents pending. Made in the U.S.A. Copyright © 2010 Holocom, Inc. All rights reserved.			